

Dalmaray Concrete Products Inc. Tank Model 10500

Model 10500 Septic, Holding, or Grease
Interceptor

10596 gal septic
10776 gal holding
89.8 gal/in

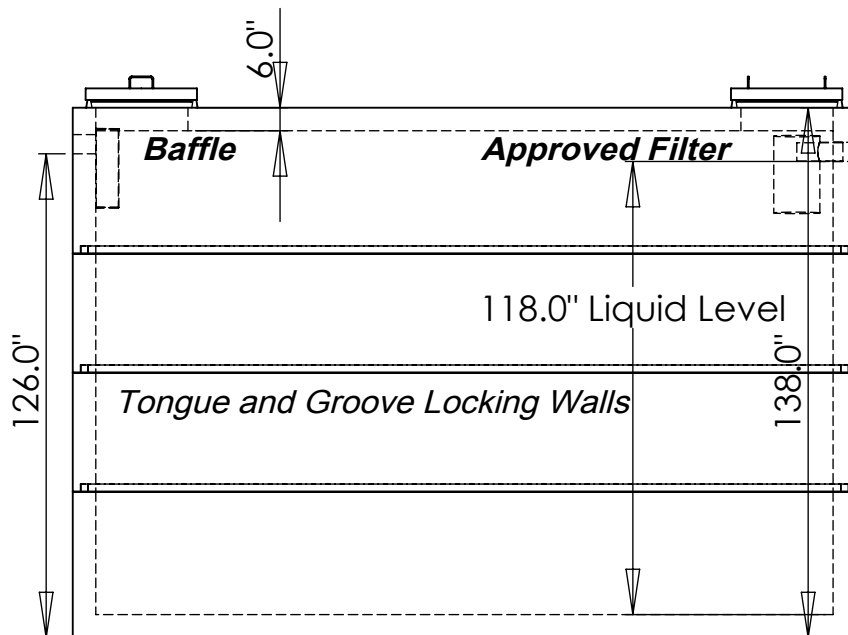
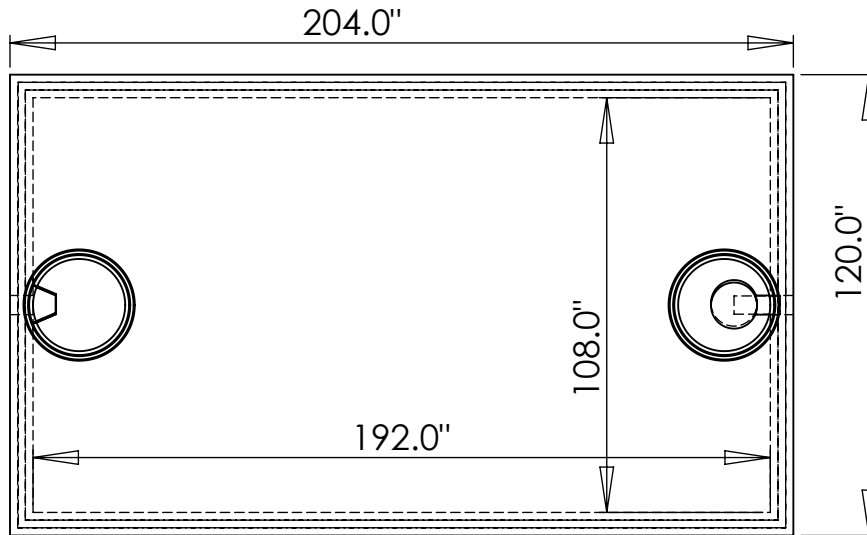

DIMENSIONS:

LENGTH - 204"

WIDTH - 120"

HEIGHT - 138"

BELOW INLET - 126"

BOTTOM SECTION WEIGHT - 24000 lb.

RISER SECTION WEIGHT - 9950 lb.

TOP SECTION WEIGHT - 24000 lb.

MAX DEPTH OF BURY 48"

Dalmaray Concrete Products Inc.

405 S. Arch St.
Janesville, WI 53548
(608)-752-6507

Toll Free: (888)-222-4541

Fax: (608)-752-5671

www.dalmarayconcreteproducts.com